

Front-End Receiver: Recent and Emerging Trend

Ulrich L. Rohde
BTU Cottbus 03046 Germany

Ajay K. Poddar
Synergy Microwave NJ USA

Enrico Rubiola
FEMTO-ST Inst. Besancon France

Marius A. Silaghi
University of Oradea, Romania

Abstract—This paper describes the recent trend of front-end receiver systems for the application in radio monitoring. The receiver implementation is optimized for applications such as hunting and detecting unknown signals, identifying interference, spectrum monitoring and clearance, and signal search over wide frequency ranges, producing signal content and direction finding of identified signals.

Keywords—Receivers, Real time FFT Processing

I. INTRODUCTION

The emerging security threats demand an intensive data gathering for fiber or radio communication [1]. Besides the fiber technology, there are varieties of wireless activities, which are typically analyzed by off the air monitoring [2]-[9]. The spectral density of signals these days is very high and therefore such monitoring receivers require high performance. The technique in designing such receivers is a composition of microwave engineering of the building blocks preamplifier, mixer, synthesizer and necessary filters, this paper describes critical aspects of important building blocks of radio monitoring receives [10]-[20].

What is needed: The following is a proposed data sheet for a surveillance receiver. The dynamic range requirements are typically the highest in the frequency range between 80 and 160 MHz, as the broadcast band is full of strong signals (80 MHz to 109 MHz) and the frequency range above covers the aircraft radio band, the amateur radio band:144-148 MHz) and the mobile communication above the 160 MHz.

II. DATA FOR RADIO MONITORING RECEIVERS [21]

| Frequency range | |
|--|--|
| Basic unit (receive mode) | 9 kHz to 26.5 GHz |
| Frequency setting | 1 kHz, 100 Hz, 10 Hz, 1Hz |
| Frequency error | $\leq \pm 1.5 \times 10^{-6}$ (-10 °C to +55 °C) $\leq \pm 1 \times 10^{-7}$ |
| Frequency aging | $\leq \pm 5 \times 10^{-7}$ per year |
| Oscillator phase noise | ≤ -138 dBc (10 kHz) |
| Synthesizer settling time | ≤ 1 ms |
| Immunity to interference, nonlinearities | |
| Image frequency rejection | typ. 110 dB, ≥ 90 dB |
| IP2 | typ. 50 dBm, ≥ 40 dBm |
| IP3 | typ. 35 dBm, ≥ 28 dBm |
| Spurious | ≤ -113 dBm |
| Sensitivity | |
| Total Noise Figure (incl. AF Section) | typ. 12 dB, ≤ 14.5 dB |
| (S+N)/N ratio | measurement using telephone filter to CCITT |
| Ue = -103.5 dBm (1.5 μ V) | ≥ 10 dB |
| Ue = -47 dBm (1 mV) | ≥ 47 dB |
| FM, B=15 kHz, fmod=1 kHz, deviation 5 kHz | |
| 9 kHz to 26.5GHz | |
| Vin = -107 dBm (1 μ V) | ≥ 25 dB |

| | |
|---|---|
| 650 MHz to 1300 MHz | |
| 20 MHz to 650 MHz | |
| Vin = -117 dBm (0.3 μ V) | ≥ 10 dB |
| Vin = -47 dBm (1 mV) | ≥ 50 dB |
| LSB/USB, IF bandwidth 500 Hz, | |
| $\Delta f = 500$ Hz | |
| 0.5 MHz to 20 MHz, | ≥ 10 dB |
| Vin = 0.4 μ V | |
| 20 to 30 MHz, Vin = 0.5 μ V | ≥ 10 dB |
| LSB/USB, IF bandwidth 2.5kHz, | |
| $\Delta f = 1$ kHz | |
| 0.5 MHz to 20 MHz, | ≥ 10 dB |
| Vin = 0.6 μ V | |
| 20 to 30 MHz, Vin = 0.7 μ V | ≥ 10 dB |
| Vin = 100 μ V | ≥ 46 dB |
| AM, IF Bandwidth 2.5kHz, fmod=1 kHz, m=0.5 | |
| 0.5 MHz to 20 MHz, | ≥ 10 dB |
| Vin = 1 μ V | |
| 20 to 30 MHz, Vin = 1.2 μ V | ≥ 10 dB |
| Crossmodulation interfering signal 2.5 V (+21 dBm), | |
| SINAD | ≥ 20 dB |
| Demodulation | AM, FM , LOG,PULSE; SSB and CW optional |
| Squelch | signal controlled, adjustable -10 dB μ V to 80dB μ V (max. 110 dB μ V, 120 dB μ V) |
| AGC range | 90 dB; 1 μ V to 10 mV makes ≤ 4 dB difference in AF level |
| RF attenuator 30 dB selectable or | signal-controlled |
| AGC speed for 90 dB range | Attack Decay AM/B=15 kHz <15 ms 15 ms Pulse/B=100 kHz <0.1 ms 3 s, corr. to SSB/B=2.5 kHz <1 ms, 3dB/100ms |
| Range of MGC (manual gain control) EGC (external gain control) by analog voltage | |
| COR Decay Attack | |
| AFC | adjustable 1 s to 10 s ≤ 25 ms |
| Offset indication Signal-level indication | digital tuning for signals of unstable frequency graphic using tuning markers, numeric in 50 Hz steps (B ≤ 100 kHz) |
| Resolution Error | |
| Memory scan | graphic as level line or numeric from -10 dB μ V to 80 dB μ V (110 dB μ V), with tuner 0 120 dB μ V graphic 1 dB, numeric 0.1 dB $\leq \pm 3$ dB, $\leq \pm 2$ dB for level ≥ 0 dB μ V 1000 definable memory locations, each location may be allocated a complete set of receive data, up to 250 ch/s five definable start/stop frequency spans with separate receive data sets (5 jobs), up to 250 ch/s full receive range (max. 650 MHz) or any expanded |
| MSCAN | |
| Frequency scan | |
| FSCAN Analog sweep | |
| ASCAN (option) | |

| | |
|--|---|
| | section |
| Spectrum Scan | 1/2/5/10/20/50/100/200/500kHz 1/2/5/10/20/140/180/ 500 MHz added for receiver tuning approx. 47 ms IF filters of receiver |
| (Base Unit) Frequency marker Sweep time Resolution filter | |
| $\Delta f \geq 30$ kHz; $m = 0.3$; $f = 1$ kHz, signal level 5 mV (-33 dBm) | |
| modulation transfer | $\leq 10\%$ |
| Blocking interf. signal 3.15 V (+23 dBm), $\Delta f \geq 30$ kHz | |
| signal level 500 μV (-53 dBm), $m = 0.3$, $f = 1$ kHz signal attenuation | ≤ 1 dB |
| Desensitization interf. signal 150 mV (-3.5 dBm), $\Delta f \geq 30$ kHz, signal level 15 μV (-83.5 dBm), bandwidth 2.5 kHz | |

Radio monitoring receivers must be able to process antenna signals with high cumulative loads and wide dynamic range [1]-[2]. Unknown signals are normally detected using high-speed scans over wide frequency ranges and then analyzed in detail in fixed frequency mode. A radio monitoring receiver's scan speed and probability of intercept (POI) are determined by its real-time bandwidth, sensitivity and the type and speed of signal processing employed. In particular, seamless real time processing is a requirement that other receivers do not meet. To support real-time processing, large-bandwidth and dynamic range is needed without compromising sensitivity. Some radio monitoring receivers feature multiple, switchable broadband receive paths [3].

The digital signal processing (DSP) module is the key to monitoring the required task and performance. High performance radio monitoring receivers feature DSP computing power so high that up to four times the number of FFT points actually needed is available, depending on the selected real time bandwidth [4]. By selecting an appropriate FFT length, even closely spaced channels can be reliably detected as discrete channels [5].

By utilizing the higher number of FFT points available, the FFT can be expanded by up to four times. The high computing power can also be used to perform FFT calculation using overlapping windows. This makes even short pulses clearly discernible in the spectrum's waterfall display [6].

As shown in Figures (1)-(4), signal processing is generally referred to as seamless (gapless), although pulses may go undetected if they are very short and located at an unfavorable position with respect to the FFT frame (see upper processing step in the figure "Overlapping FFT").

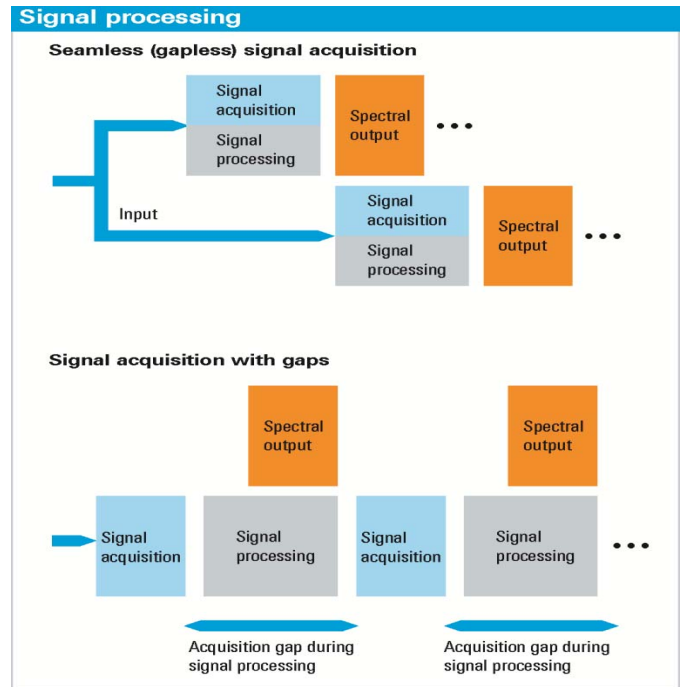

Fig. 1: Signal Processing architecture

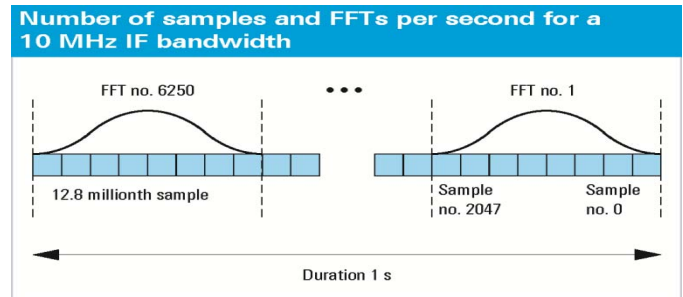

Fig. 2: Number of samples and FFTs per second for a 10MHz IF BW

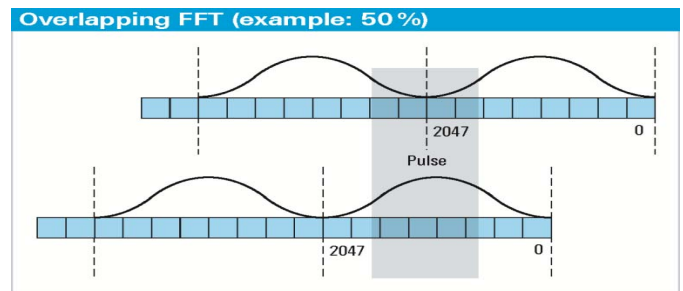

Fig. 3 Example of Overlapping FFT (50%)

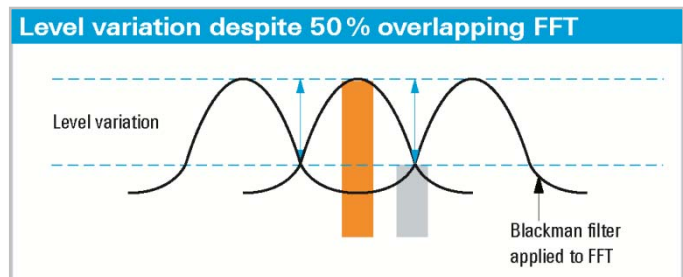

Fig. 4 Level variation despite 50% overlapping FFT

Therefore, some receivers offer overlapping FFT. Two FFTs whose frames are shifted with respect to one another are calculated in parallel from the data stream [7].

A sample located in the minimum of the Blackman filter curve of one FFT will then be found in the maximum of the other. For a real time bandwidth of 10 MHz as used in this example, minimum signal duration of 240 μ s is required to ensure 100 % reliable signal acquisition and correct level measurement [8].

For shorter pulses, the level may not be displayed correctly, but only very weak signals may go undetected. It is evident that the use of digital signal processing in a radio monitoring receiver offers great advantages [9]. Extremely high sensitivity (due to very fine resolution) combines with a broad spectral overview and high scan speed to significantly increase the probability of intercept over analog receivers or spectrum analyzers [18].

In the panorama scan mode, the spectrum is displayed across a frequency range far wider than the radio monitoring receiver’s real time bandwidth. This mode provides users with a quick overview of the spectrum occupancy. The principle of the fast spectral scan (panorama scan) is described in the following using a receiver with up to 20 MHz real time bandwidth (such as the R&S®EB500) [21]. During the scan, frequency windows of a maximum of 20 MHz width is linked in succession, so that the complete, predefined scan range is traversed shown in Figure (5), illustrates the “signal processing in panorama scan mode”.

As is done for the IF spectrum, an FFT is used to process the broad window with a finer resolution. The width of the frequency window and the FFT length (number of FFT points) are variable and are selected by the receiver automatically. The user can select among 24 resolution bandwidths from 100 Hz to 2 MHz. The resolution bandwidth corresponds to the width of the frequency slices (bin width) mentioned under “IF spectrum”.

Based on the selected bin width and start and stop frequency, the monitoring receiver automatically determines the required FFT length and the width of the frequency window for each scan step. The receiver selects these internal parameters so that the optimum scan-speed is achieved for each resolution bandwidth shown in Figure (6), illustrates “Resolution in panorama scan mode”.

The highest resolution bandwidth of 2 MHz yields the maximum scan speed, while the smallest resolution bandwidth of 100 Hz yields maximum sensitivity. The resolution bandwidth (bin width) for the panorama scan (selectable between 100 Hz and 2 MHz) therefore corresponds to the resolution bandwidth (BW_{bin}) used in the displayed noise level (DNL) calculation for the IF, and can be used for calculating the DNL for the panorama scan as:

$$DNL = -174 \text{ dBm} + NF + 10 \times \log(BW_{bin}/\text{Hz}) \quad (1)$$

The quantity NF represents the overall noise figure of the receiver. The user selects the resolution bandwidth to obtain the desired frequency resolution shown in Figure (7), illustrates “Bin width and channel spacing”.

A receiver’s available IF bandwidth has a direct influence on the achievable panorama scan speed. Doubling the IF bandwidth (i.e. using 20 MHz instead of 10 MHz in this example) will also double the achievable scan speed. If the IF bandwidth is increased from 20 MHz to 80 MHz, the scan speed can be boosted by a factor of four.

The above explanations show that the use of digital signal processing in a radio-monitoring receiver offers decisive advantages. Extremely high sensitivity (due to very fine resolution) combined with a broad spectral overview and maximum scan speed significantly increases the probability of intercept as compared with an analog receiver.

As the number crunching of analog to digital converters improves, 1 GHz clock frequency has already been achieved, better performance will be possible. The systems performance is determined by hardware, firmware and software. Even if everyone has access to the same chipset the implementation may differ depending upon the market price of the equipment. Not everyone needs the high-end systems.

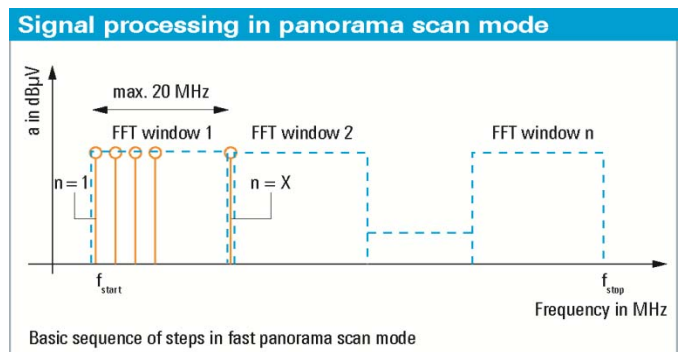

Fig. 5 Signal Processing in Panorama scan mode

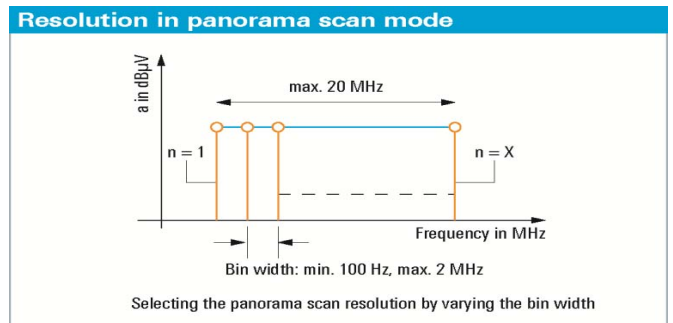

Fig. 6 Resolution in Panorama Scan Mode

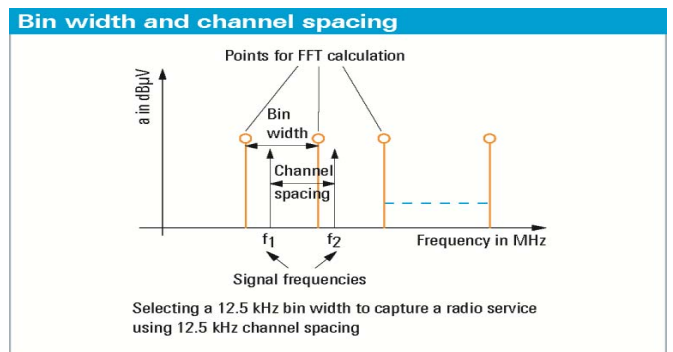

Fig. 7 Bin Width and Channel Spacing

III. RECEIVER CONCEPT

The rapidly advancing in development of components for digital signal processing and the rapid rise of processing power enables more and more new concepts in the implementation of so called Software Defined Radios (SDR). The SDR approach includes transmitter and receiver concepts, whereas the signal processing is largely done in programmable devices, such as field programmable logic arrays (FPGA) and digital signal processors (DSP). Thereby, components that have been typically implemented in hardware (e.g. amplifiers, mixers, filters, modulators, etc.) are instead implemented by means of software on a digital signal processing platform. Thus, hardware is replaced by software. A software defined radio platform has the advantage of being able to make functional changes on a receiver or transmitter to meet new requirements quickly. Thus it is possible to keep these products up to date for a long period. A typical example is the mobile telephone according the various GSM, UMTS and LTE standards. Even inexpensive amateur radio use more and more of this modern technology, because of the increasing integration of available DSP and FPGA modules and the performance enhancement of microprocessors, accelerating the application in this price segment.

The SDR approach is making use of time discrete signal processing by sampled signals. Such sampled systems have been published first in 1985 [9]-[10]. The typical receiving frequency range is 9 KHz to 55 MHz given a typical sampling frequency of 125MHz, with a resolution equal to 16 bit. The latest 16 bit Analog-to-Digital Converters (ADC) offer a range up to 110MHz, at a sampling frequency of 250MHz. The key element in a SDR receiver is the analog-to-digital converter. This device is placed ideally as close as possible to the antenna. For VHF (>50MHz) to SHF frequencies however, there is a need to place an analog down converter in front of the AD converter. All signal processing components following the AD converter are widely free from tolerances, noise, unwanted couplings and profit from a high reproducibility and a zero drift. The software configurable hardware components and DSP algorithms allow a maximum product flexibility.

The analog front-end in Figure (8) may consist of pre-selector filters, a pre-amplifier and, if needed, a frequency converter. The preconditioned signal is then passing the AD-Converter, which is producing a sampled discrete time representation of the analog, time invariant input signal. The output data rate of the AD Converter (i.e. the product of sample rate times resolution) is in the range of 1...4Gbit/s. This data stream may consist of the whole spectrum from DC up to the half sample rate. For most communications purposes, only a small fraction of this bandwidth is of interest, unless the implementation of several receivers in the system is wanted in special cases. Therefore it needs a single, or a number of frequency conversions with a subsequent reduction of the sample rate. This function block is designated to as the Digital Down Converter (DDC). The preconditioned digital signals are then processed at a lower data rate in the Digital Signal Processing unit. The task of the DDC is to perform the digital down conversion, decimation of the channel rate, baseband IQ generation, channel filtering, and offset cancellation, using commercially available ASICs (application specific integrated

circuits), or a programmable hardware in the form of FPGAs (field programmable gate arrays). Subsequently, the further processing as demodulation, clock and carrier synchronization, decryption, audio processing, spectrum analysis, etc. can be performed by the DSP.

A typical front-end consists of an input stage, first mixer stage including the necessary synthesizer, a possible second mixer stage, and then the output is fed to signal processing down at the IF level of choice. As seen in section II, there are varieties of important receiver parameters. The noise figure determines the minimum discernible signal sometimes also called minimum detectable signal, typically expressed in dBm and overall dynamic range, the key intermodulation distortion products [1]-[2]. System noise and noise floor defines the spurious free dynamic range. The 2nd order intermodulation distortion product can degrade the system performance; the appropriate input filters reduce this as depicted in Figure (9).

Figures (10) and (11) show the typical scheme of up/down converted for high performance receiver applications. This signal is then up-converted to an IF of about 20 GHz using a highly cleaned-up LO chain. The up-conversion of signal is achieved with the help of frequency doubler and large bank of filters, as shown in Figure (10). Spectral purity of the oscillator chain is of the essence. Finally, a second converter is used to down convert the signal to the IF level. This arrangement allows a very high performance signal analysis, as illustrated in Figure (11).

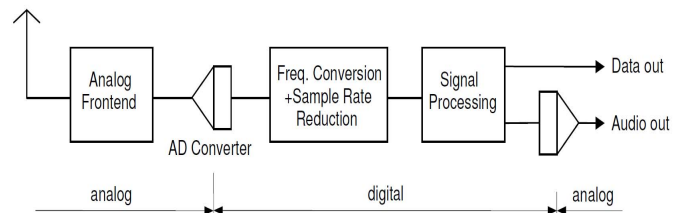

Fig. 8 General Block Diagram of a SDR Receiver

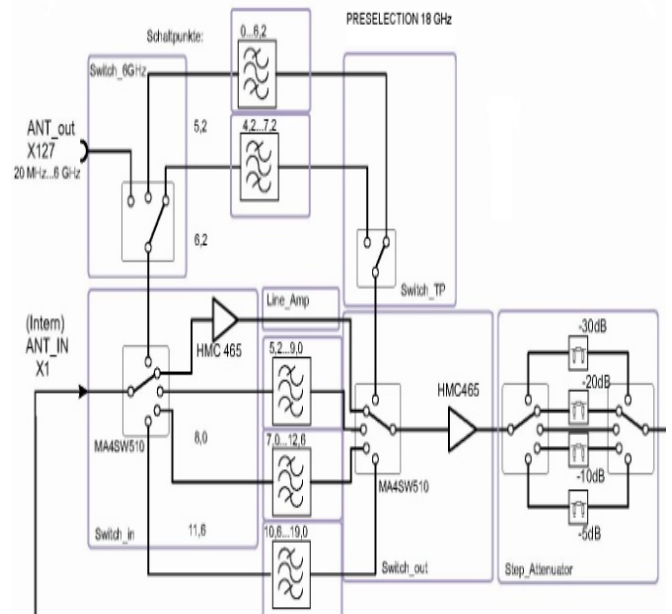

Fig. 9 Filter portion of the front-end of the receiver

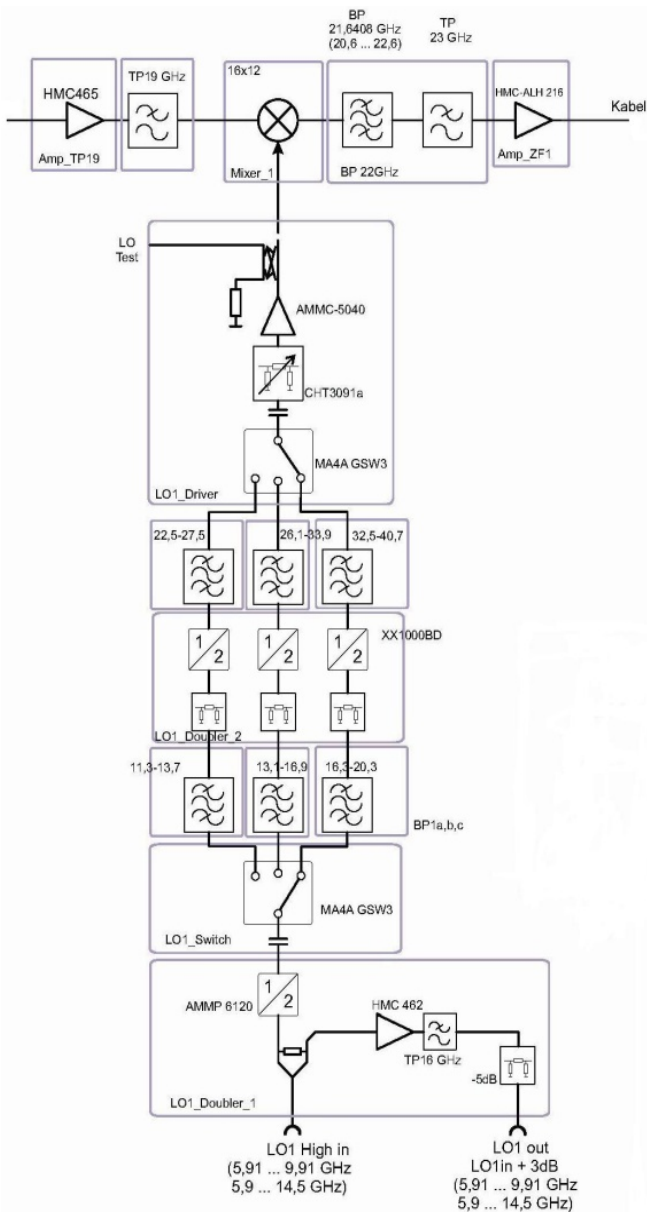

Fig. 10 Up-converter and mixer of the receiver

Figure (12) show the typical block diagram of wideband radio monitoring receiver. Figure (13) shows a frequency panorama display and a waterfall time event. On the left hand of the frequency display, there are a large number of FM broadcast stations and on the right side are an air-traffic control frequency range and police and other mobile radioactivity.

As depicted in Figure (13), the waterfall display shows the various transmissions that are useful for frequency occupancy analysis over time, and the spectral display shows a range where demodulation of transmission is possible while observing all the activity.

It can be seen that Figure (13) demonstrates the capability of high dynamic ranges; Aircraft Radio Communication Receiver can be monitored and demodulated in the presence of strong FM Radio signal. Figure (14) shows the multi-

channel operation capability, 5-channel arrangement for signal analysis. The wideband monitoring receiver can handle five individual channels simultaneously, including transmission monitoring. In this case, two ATC frequencies and two FM broadcast stations.

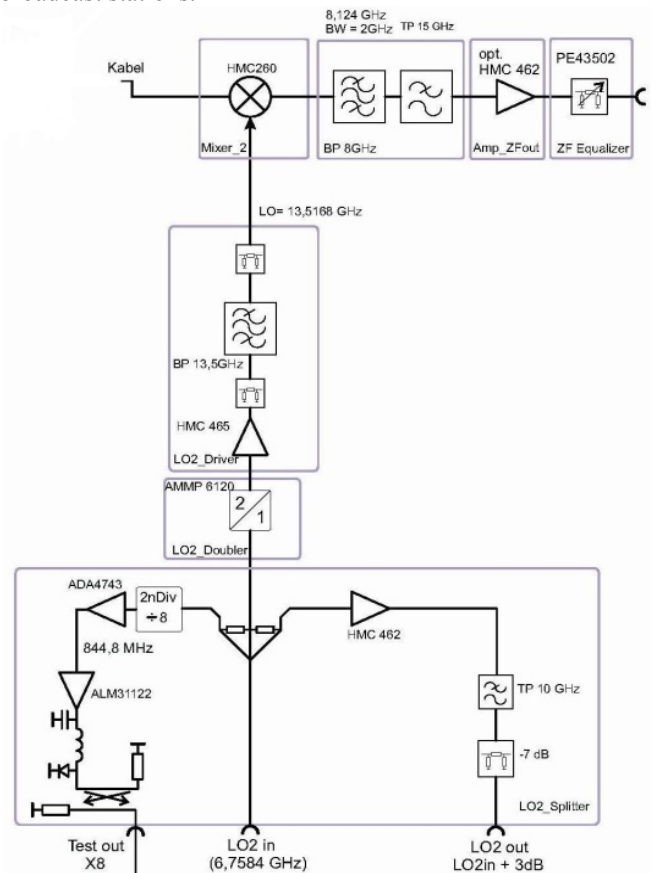

Fig. 11 A typical schematic of receiver down-converter

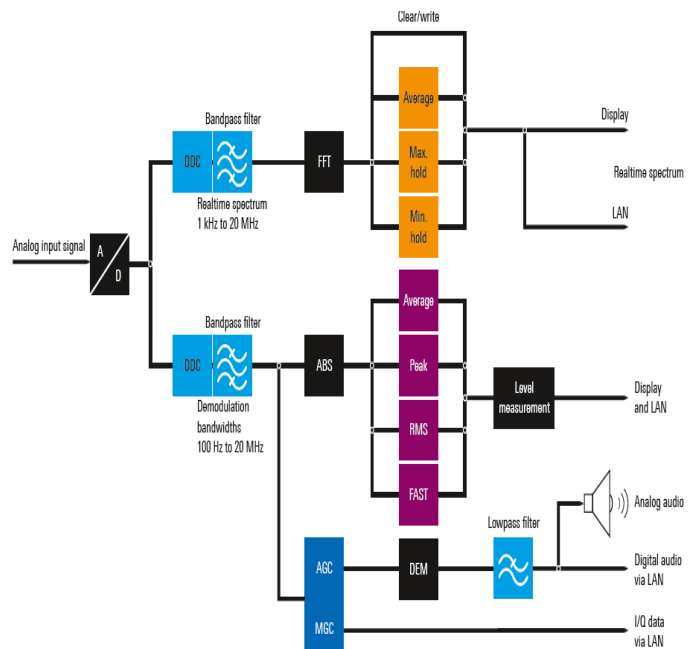

Fig. 12 Schematic of wideband monitoring RX (R&S ESMD)

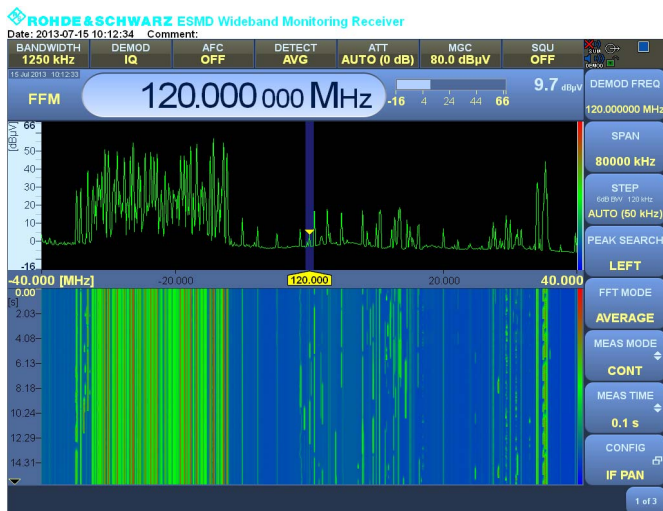

Fig. 13 Wide bandwidth waterfall (courtesy: R & S)

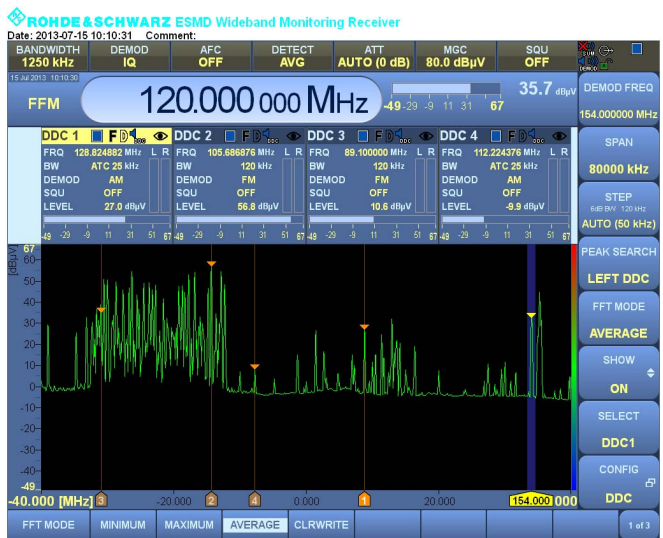

Fig. 14: Five channel arrangement for signal analysis Conclusion

It can be seen that The spectral density of signals these days is very high and therefore such monitoring receivers require high performance. Figures (12)-(14) demonstrate the capability of very high performance Radio monitoring receiver system.

IV. CONCLUSION

The systems performance is determined by hardware, firmware and software. Even if everyone has access to the same chipset the implementation may differ depending upon the market price of the equipment. Not everyone needs the high-end systems.

ACKNOWLEDGEMENT

We would like to thank Rohde & Schwarz for making the latest hardware information and specifications available. We actually have one of those surveillance systems, which allow us to monitor the radio amateur frequencies and other bands of interest. The surveillance system is connected to a variety of

active antennas as passive antennas are too frequency selective. The dynamic range of active antennas is another topic of interest for further investigation.

REFERENCES

- [1] Ulrich L. Rohde and David Newkirk, "RF/Microwave Circuit Design for Wireless Applications", John Wiley & Sons, April 2000, ISBN 0-471-29818-2
- [2] Ulrich L. Rohde, Jerry Whitaker, "Communications Receivers", Third Edition, McGraw-Hill, Dec. 2000, ISBN 0-07-136121-9
- [3] K. McClaning, T. Vito, *Radio Receiver Design*, 1959.
- [4] James Tsui, *Special Design Topics in Digital Wideband Receivers*, 2010
- [5] Behrouz Farhang-Borjieny, *Signal processing Techniques for Software Radios*, 2008
- [6] J. Proakis; U. Rohde, "The Wiley Encyclopedia of Telecommunications: "Frequency Synthesizers", Wiley 2004.
- [7] Ulrich L. Rohde, "How Many Signals Does a Receiver See?" Ham Radio Magazine, June, 1977, pg. 58.
- [8] Ulrich L. Rohde, "Recent Developments in Communication Receiver Design to Increase the Dynamic Range", ELECTRO/80, Boston, MA, May 1980
- [9] U. L. Rohde, "Digital HF Radio: A Sampling of Techniques, presented at the 3rd International Conf. on HF Communication Systems and Techniques", England, February 26-28, 1985
- [10] Ulrich L. Rohde, "Digital HF Radio: A Sampling of Techniques", Ham Radio Magazine, April, 1985
- [11] Ulrich L. Rohde, "A Comparison of Solid State and Tube Based Receiver Systems Using CAD", QST June, 1993, pp. 24-28
- [12] U. Rohde, "Modern Receiver Design Including Digital Signal Processing", UHF-VHF Conf., Germany, March 9-10, 1996
- [13] Ulrich L. Rohde, Hans H. Hartnagel, "The Dangers of simple usage of Microwave Software", www.mes.tu-darmstadt.de/media/mikroelektronische_systeme/pdf_3/ewme2010/proceedings/sessionvii/rohde_paper.pdf
- [14] Ulrich L. Rohde, "Eight Ways to Better Radio Receiver Design", Electronics, February 20, 1975
- [15] Ulrich L. Rohde, "Harmonic Balance Method Handles Non-Linear Microwave CAD Problems", MW Journal, October 1987
- [16] Ulrich L. Rohde, "I-F Amplifier Design", Ham Radio Magazine, March, 1977
- [17] Ulrich L. Rohde, "Key Components of Modern Receiver Design", Parts I, II and III, QST, May, 1994 pp. 29 -32, June, 1994 pp. 27 - 30, July 1994, pp. 43 45, respectively
- [18] Ulrich L. Rohde, "Low-Noise Source Uses Hetero-junction Bipolar Transistor", *Microwaves & RF*, February 1989
- [19] Ulrich L. Rohde, "Active Antennas", *RF Design*, June 1981
- [20] Robert C. Dixon, *Radio Receiver Design*, 1932
- [21] ESMD Wideband Monitoring System, Rohde & Schwarz
- [22] U. L. Rohde, A. K. Poddar, "A Digital Frequency Synthesizer Using Adaptive Mode-Coupled Resonator Mechanism for Low Noise and Low Jitter Applications", IEEE-ISCAS, pp. 414-417, May 15-18, 2011, Brazil
- [23] U. Rohde, A. Poddar, "A Novel High Frequency Synthesizer Using Adaptive Injection Mode-Coupled VCISO for Low Jitter and Low Noise Applications", *Proceedings of 2011 Joint Conference of the IEEE IFCS & EFTF*, pp. 452-457, May 2011
- [24] U. Rohde, A. Poddar, "Adaptive Mode-Coupled Harmonically Tuned Ultra Low Phase Noise VCISO Circuits", *Proceedings of Joint Conf. of the IEEE IFCS & EFTF*, 452-457, May 2011.
- [25] U. Rohde, A. Poddar, "Frequency Generation and Synthesis: Configurable, Concurrent, Cost-Effective and Power-Efficient Solutions", *12th International Symposium on Microwave and Optical Technology (ISMOT)*, December 2009, India.